

OPERABLE WALL (Folding)

Note: You will need to purchase the appropriate hardware for your wall conditions.
Anchors not included.

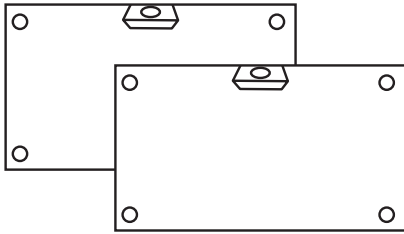

Parts Included

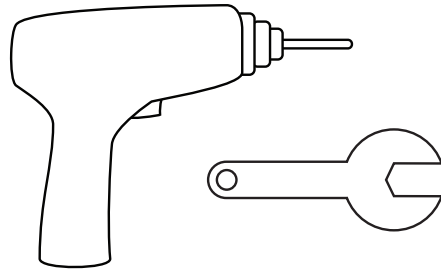

Recommended Tools

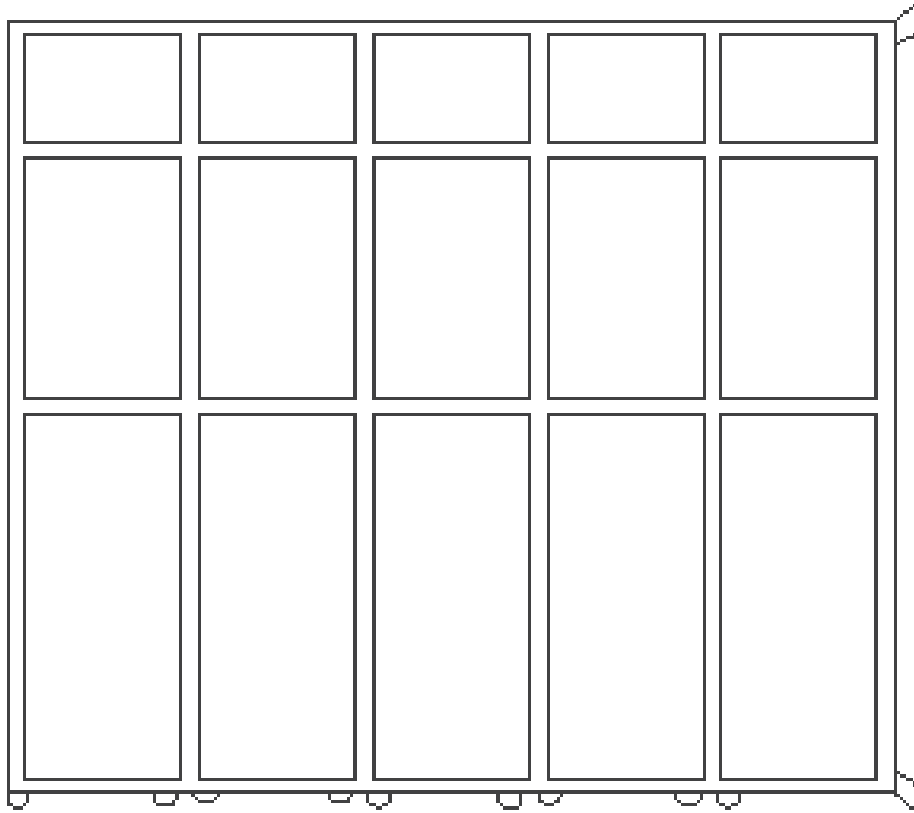

1

Remove screws from bottom panels.

(Top Panels)

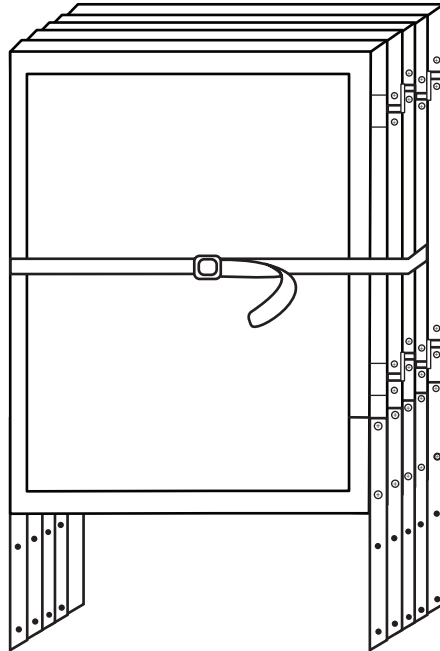

(Bottom Panels)

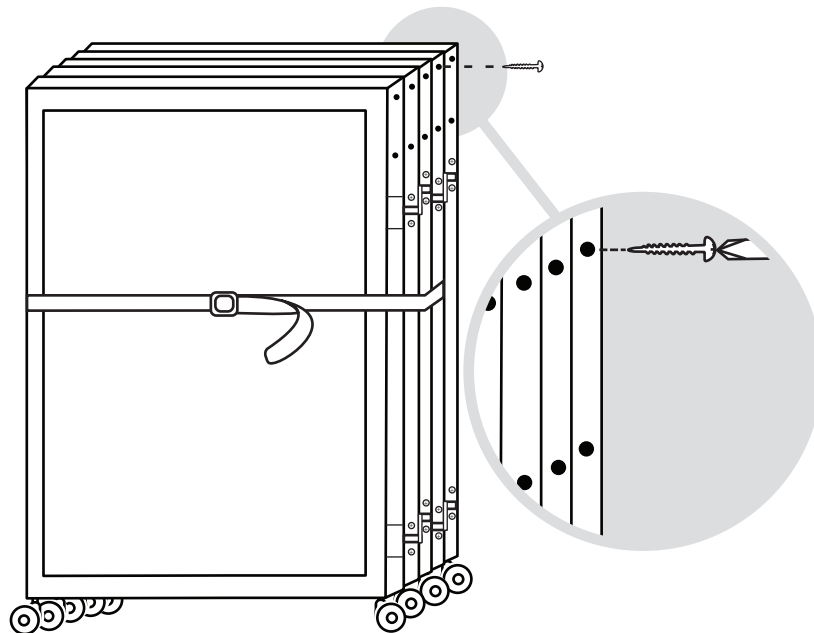

2

Connect top and bottom panels. Then reinsert screws.

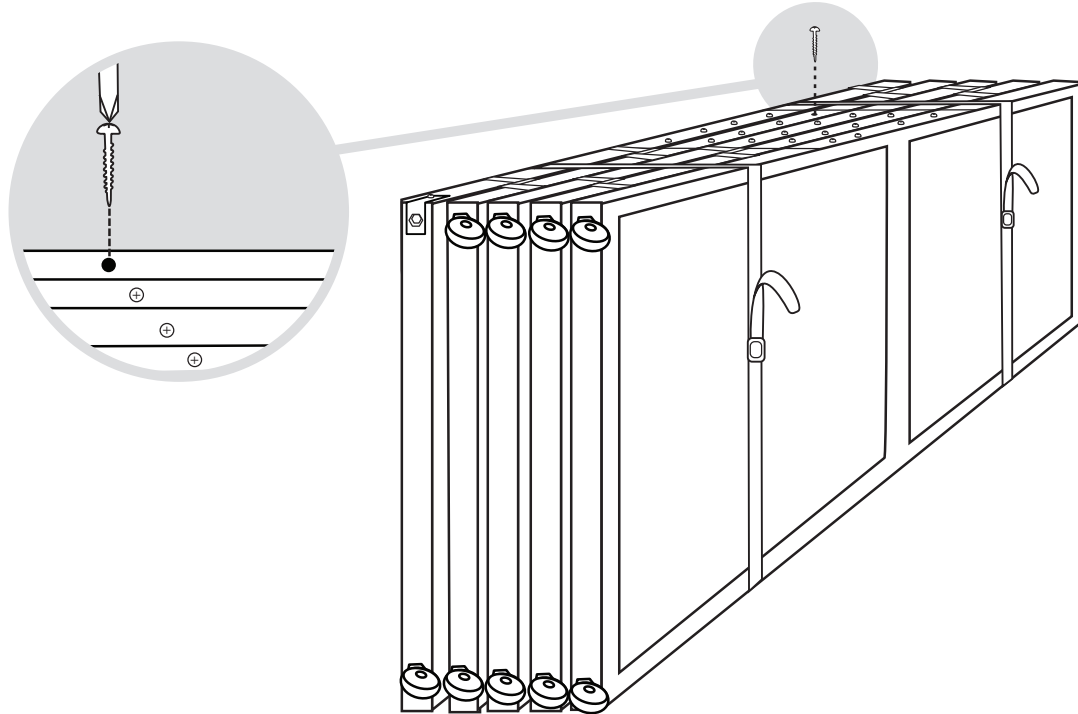

3

Attach wall mount hinges.

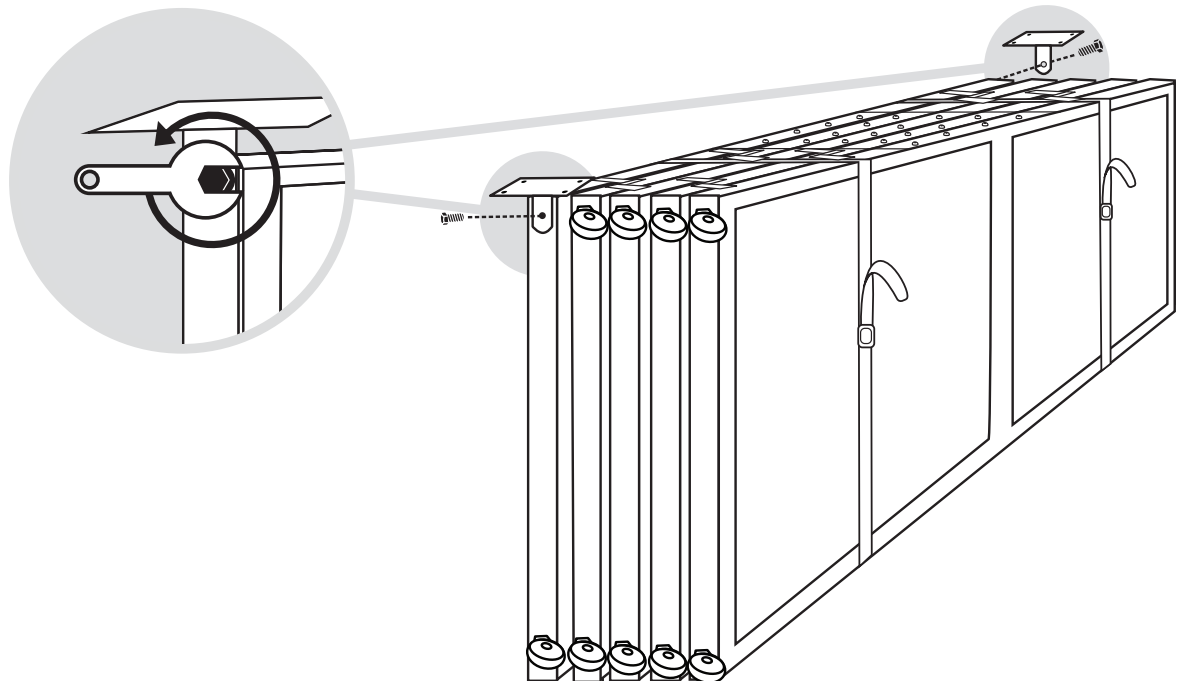

P: 1.800.830.0210
F: 1.800.310.4874

VERSARE
www.versare.com

3236 California St. NE
Minneapolis, MN 55418

4

Stand up the partition and screw hinges onto wall.

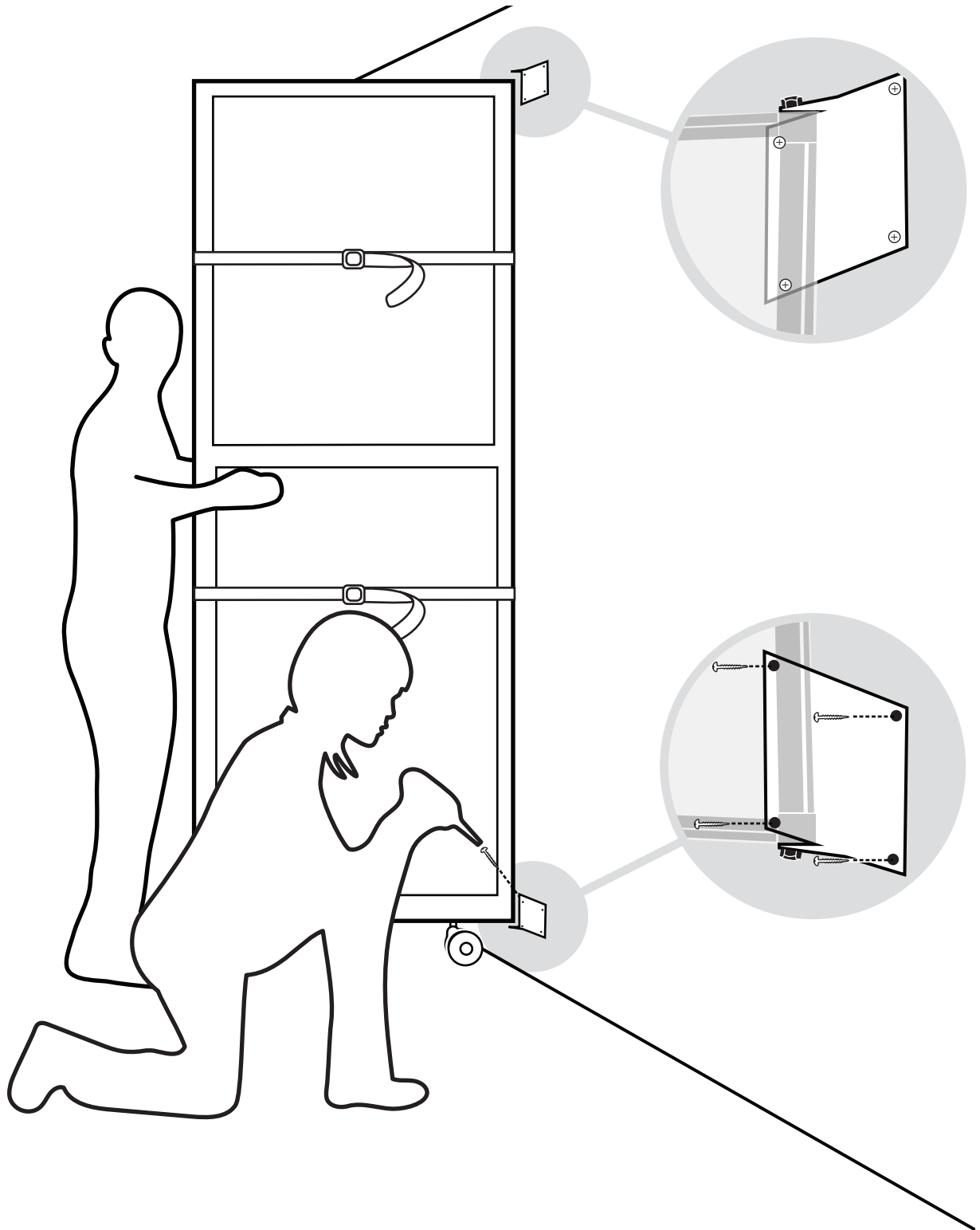

P: 1.800.830.0210
F: 1.800.310.4874

VERSARE
www.versare.com

3236 California St. NE
Minneapolis, MN 55418

7

Unbuckle straps.

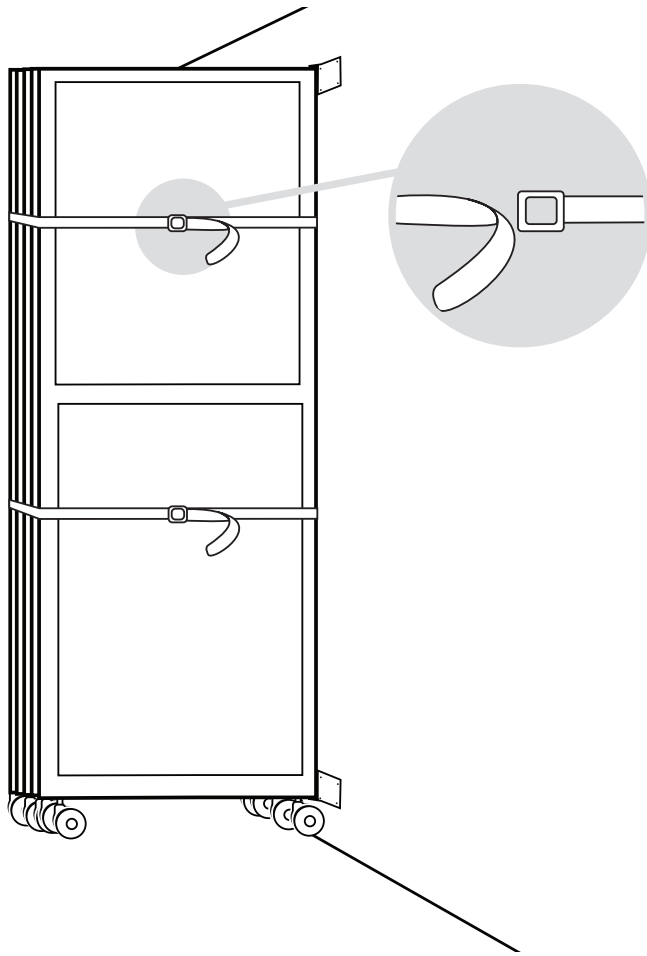

All complete!
We hope you enjoy your new
Operable Wall!

If you have any questions on your Operable Wall, please contact us at
1.800.830.0210 or
customerservice@versare.com



P: 1.800.830.0210
F: 1.800.310.4874

VERSARE
www.versare.com

3236 California St. NE
Minneapolis, MN 55418