

# Work Station Screen

## Assembly Instructions

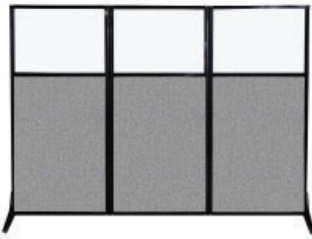

Hardware included:

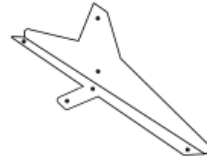

Feet



Bolts



Screws



Button  
Screws



Foot Pads

1.

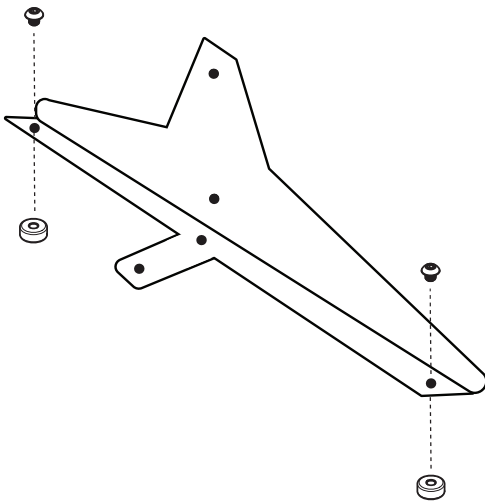

Insert button head screw down into foot end and secure with two washers and a nut. Repeat for other side of foot. Repeat for second foot.

2.

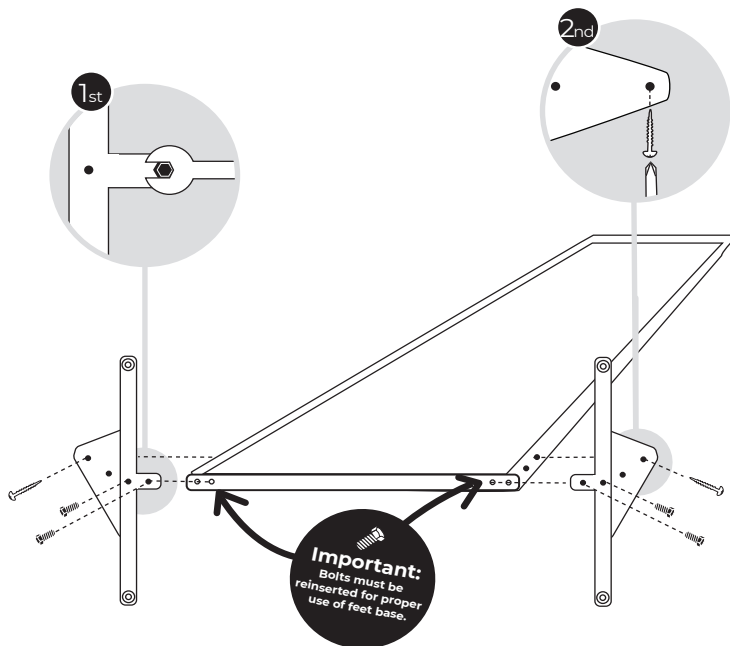

Remove two bolts from outside, bottom edge of outer panel(s) and one screw from the side of outer panel(s). Then attach foot base with **bolts first**, screws second. Repeat for other side.

3.

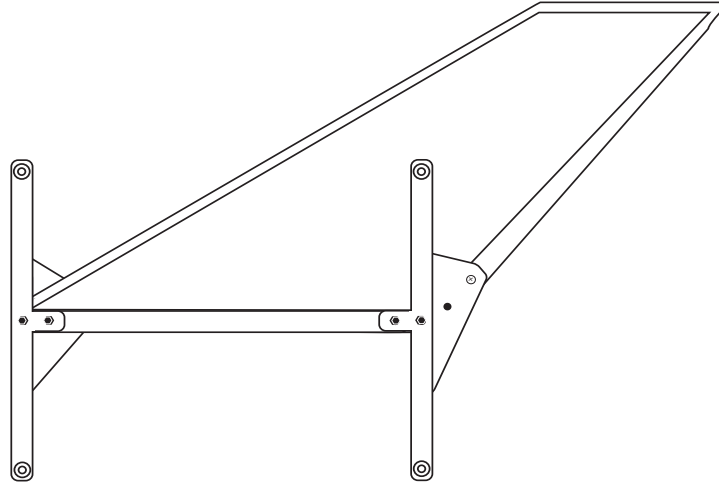

Assembly complete!  
We hope you enjoy your new Work Station!

For questions regarding your Work Station please contact us at  
1-855-457-1473 or  
customerservice@versare.com



**VERSARE**

Versare Solutions, LLC  
3236 California St. NE • Minneapolis, MN 55418  
1-855-457-1473 • customerservice@versare.com

100032 REV D