



# ROOM DIVIDER SWING DOOR

## ASSEMBLY INSTRUCTIONS

### STEP 1.

Remove the two top screws from the divider frame.

### STEP 2.

Using the included grease packet, apply a small dab of grease to the swivel pivot pin. Place and click the swivel in on bottom edge of the frame.

### STEP 3.

Position the door onto the swivel, making sure it is securely seated in the swivel.

### STEP 4.

Secure the door with the screws from Step 1. Tighten with the Allen wrench provided.

#### HARDWARE INCLUDED:

- Door Panel
- Swivel
- Screws
- Allen Wrench
- Grease Packet

**Note:** The screws come preinstalled in the divider frame upon delivery. You will remove and reuse them during assembly as outlined in the instructions.

Questions or concerns regarding parts?  
Please contact us at 1.800.830.0210 or email us at [customerservice@versare.com](mailto:customerservice@versare.com)

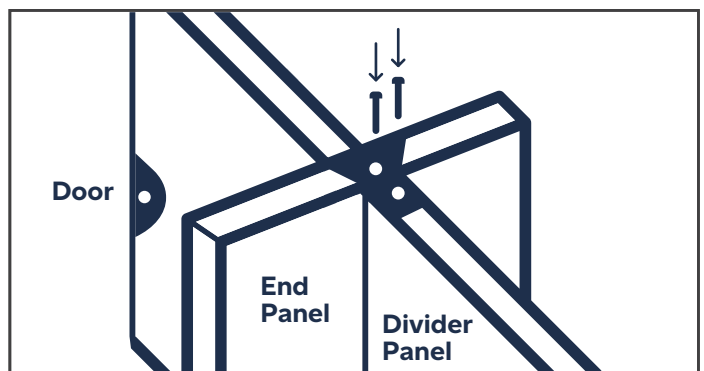
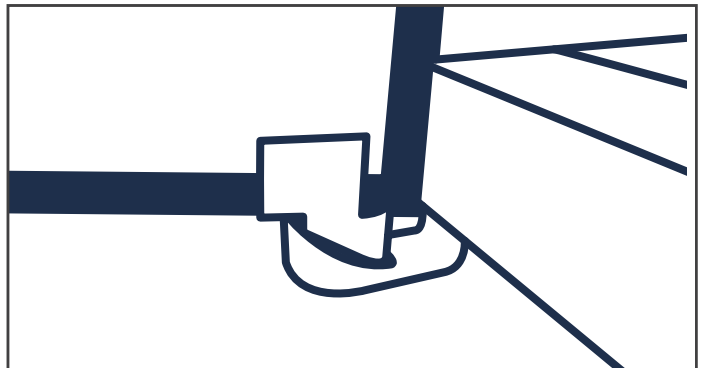
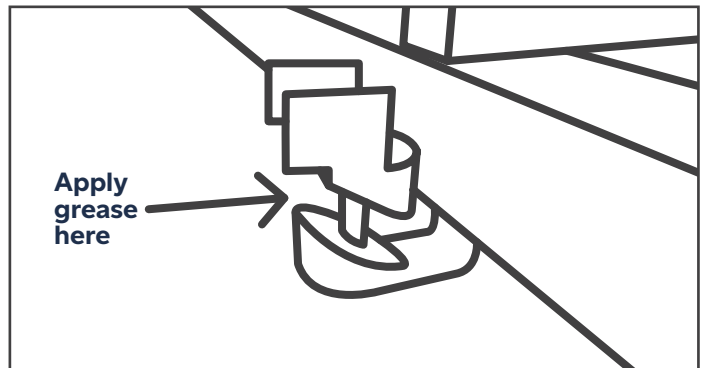
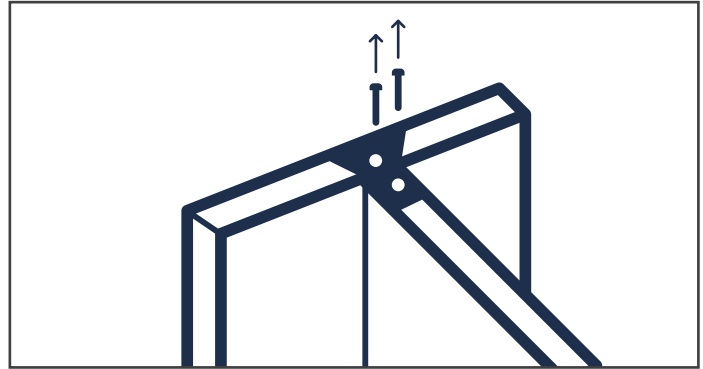



# RETROFITTED ROOM DIVIDER SWING DOOR

## ASSEMBLY INSTRUCTIONS

### STEP 1.

Remove the two top screws from the divider frame.

### STEP 2.

Remove the four bottom screws from the bracket on the underside of the end panel.

### STEP 3.

Using the included grease packet, apply a small dab of grease to the swivel pivot pin. Replace bottom bracket with swivel bracket and place back in the two screws to secure.

### STEP 4.

Position the door onto the swivel, making sure it is securely seated in the swivel.

#### HARDWARE INCLUDED:

- Door Panel
- Swivel
- Screws
- Allen Wrench

**Note:** The screws come preinstalled in the divider frame upon delivery. You will remove and reuse them during assembly as outlined in the instructions.

Questions or concerns regarding parts?  
Please contact us at 1.800.830.0210 or email us at [customerservice@versare.com](mailto:customerservice@versare.com)

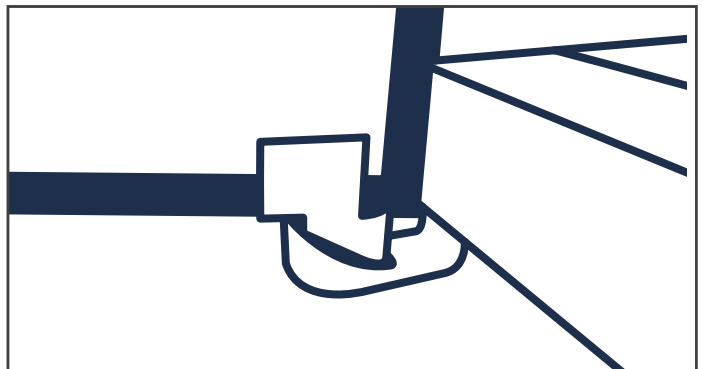
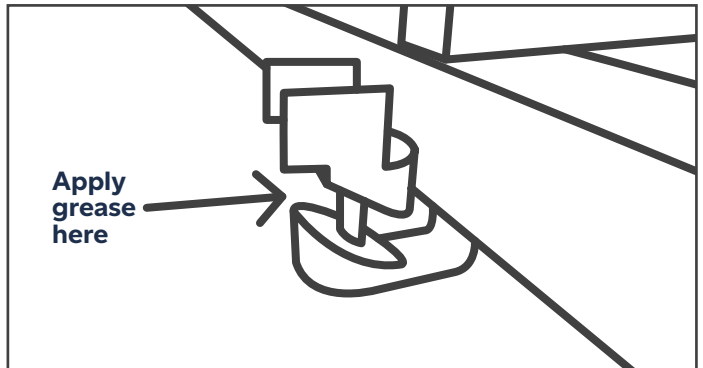
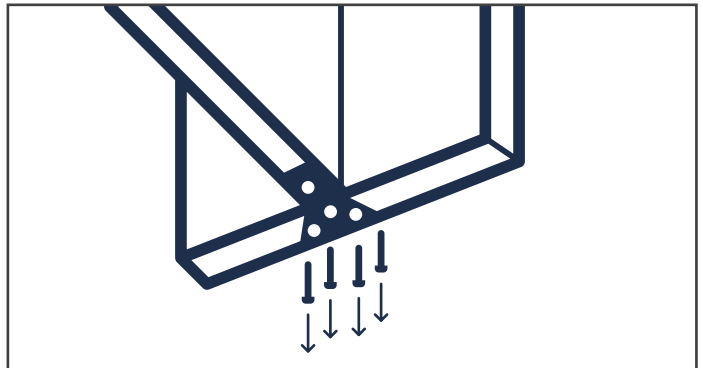
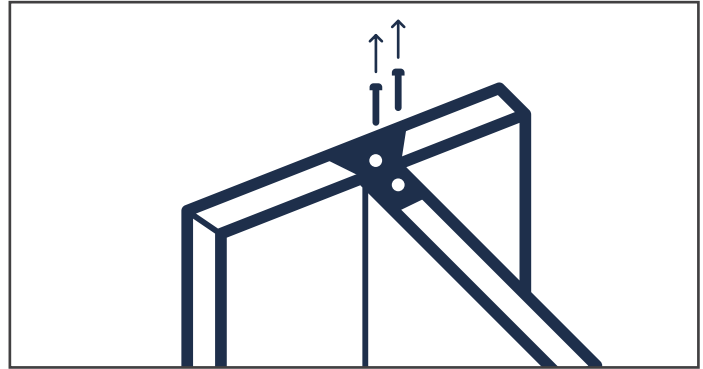



# RETROFITTED ROOM DIVIDER SWING DOOR

ASSEMBLY INSTRUCTIONS CONTINUED

## STEP 5.

Secure the door with the screws from Step 1. Tighten with the Allen wrench provided.

### HARDWARE INCLUDED:

- Door Panel
- Swivel
- Screws
- Allen Wrench

**Note:** The screws come preinstalled in the divider frame upon delivery. You will remove and reuse them during assembly as outlined in the instructions.

Questions or concerns regarding parts? Please contact us at 1.800.830.0210 or email us at [customerservice@versare.com](mailto:customerservice@versare.com)

