

Operable Wall Folding Room Divider

Assembly Instructions

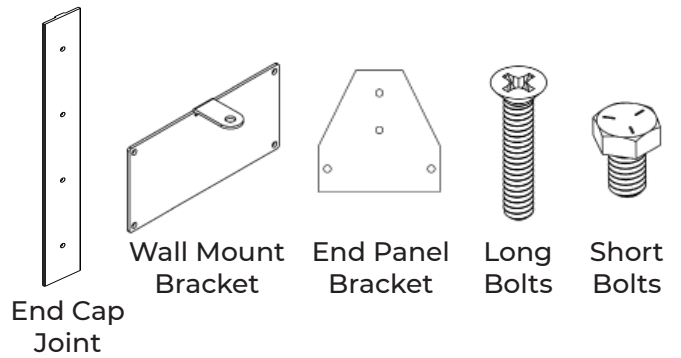

Hardware included:



End Cap Joint
Front



End Cap Joint
Back

1.

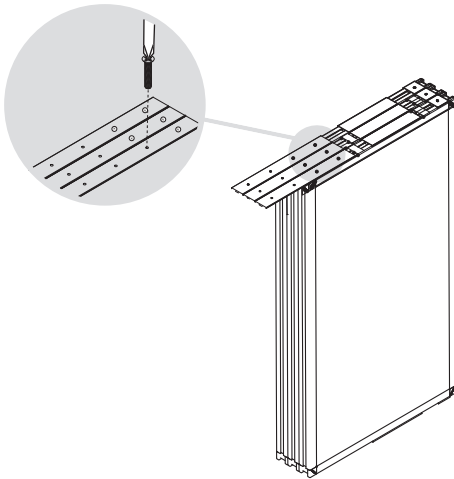

Remove the long bolt from the side of each of the top panels.* Slide first end cap joint into each top panel, leading with end A, front side facing up. Align holes and insert two long bolts. Repeat for each panel.



Helpful Tips:

*Keep shipping wrap on for easier assembly.



VERSARE

Versare Solutions, LLC
3236 California St. NE • Minneapolis, MN 55418
1-855-457-1473 • customerservice@versare.com

2.

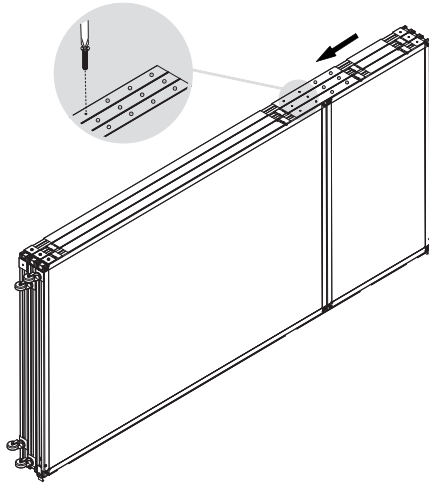

Remove a long bolt from each bottom panel. Align top and bottom panels, positioning end cap joint so holes align.** Insert two long bolts per end B of end cap joint on top panel.

3.

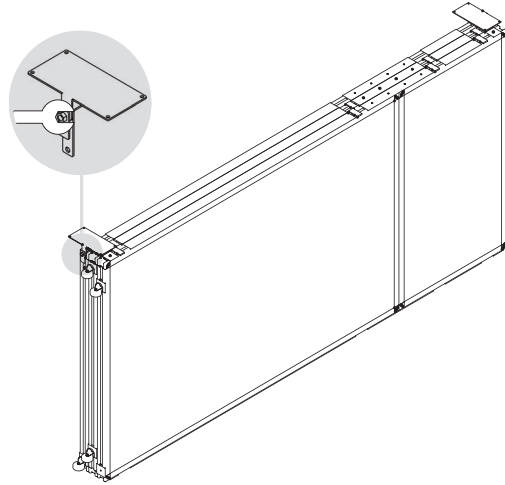

Attach wall mount hinges using bolts attached to wall mount bracket.

4.

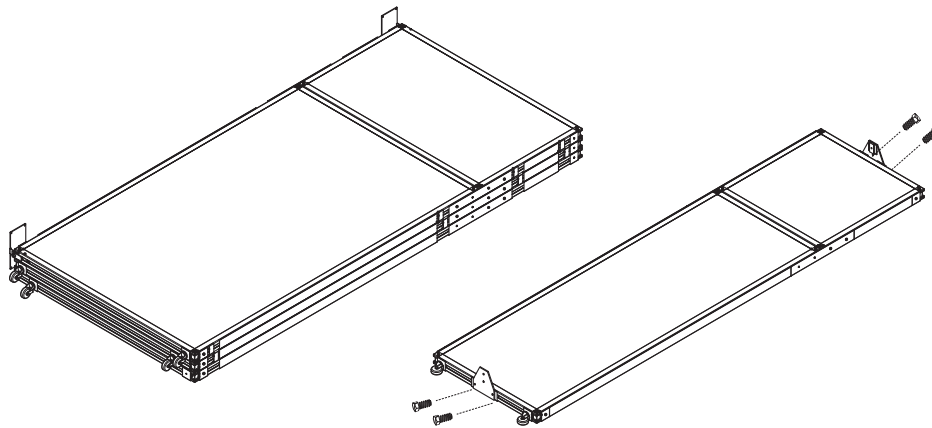

Gently place end panel flat on the ground and attach an end panel plate loosely to the top and bottom using two short bolts per plate.



VERSARE

Versare Solutions, LLC
3236 California St. NE • Minneapolis, MN 55418
1-855-457-1473 • customerservice@versare.com

5.

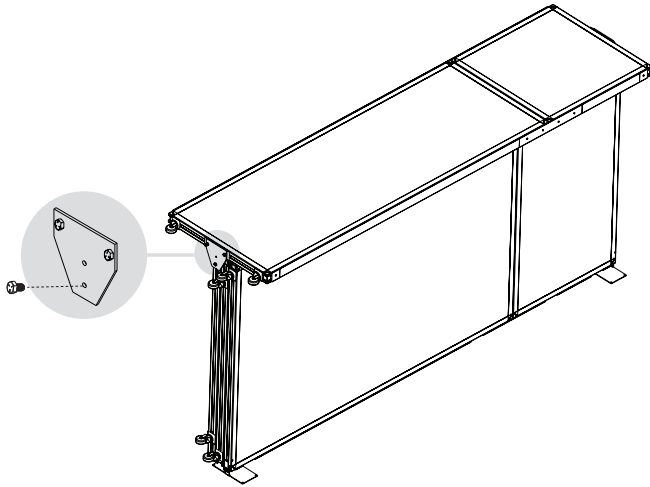

Attach end panel and plates to the main panels using one more short bolt for each plate.

6.

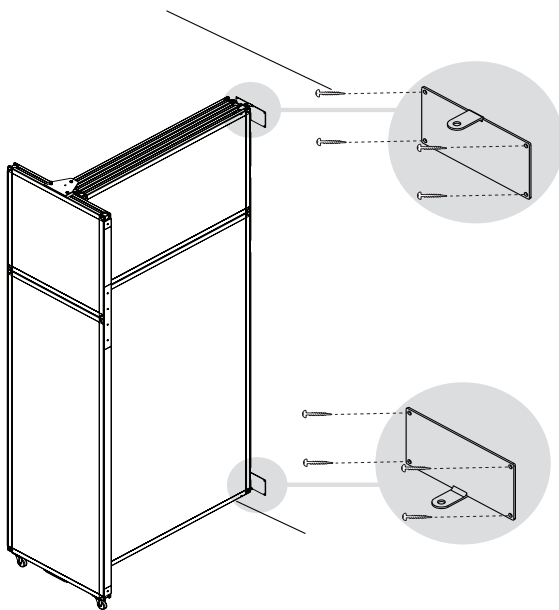

Gently lift partition onto its base and screw wall plates to wall with 4 fasteners each.**

**Due to differing wall types fasteners are not included with wall plates. Please evaluate wall material and consult local hardware professional before installing wall plates to wall for a secure installation.

Assembly complete!
We hope you enjoy your new Operable Wall Folding Room Divider!

For questions regarding your Operable Wall Folding Room Divider please contact us at
1-855-457-1473 or
customerservice@versare.com



Versare Solutions, LLC
3236 California St. NE · Minneapolis, MN 55418
1-855-457-1473 · customerservice@versare.com