

Portable Equipment Shelter

Assembly Instructions

Note: Setup will require at least two people

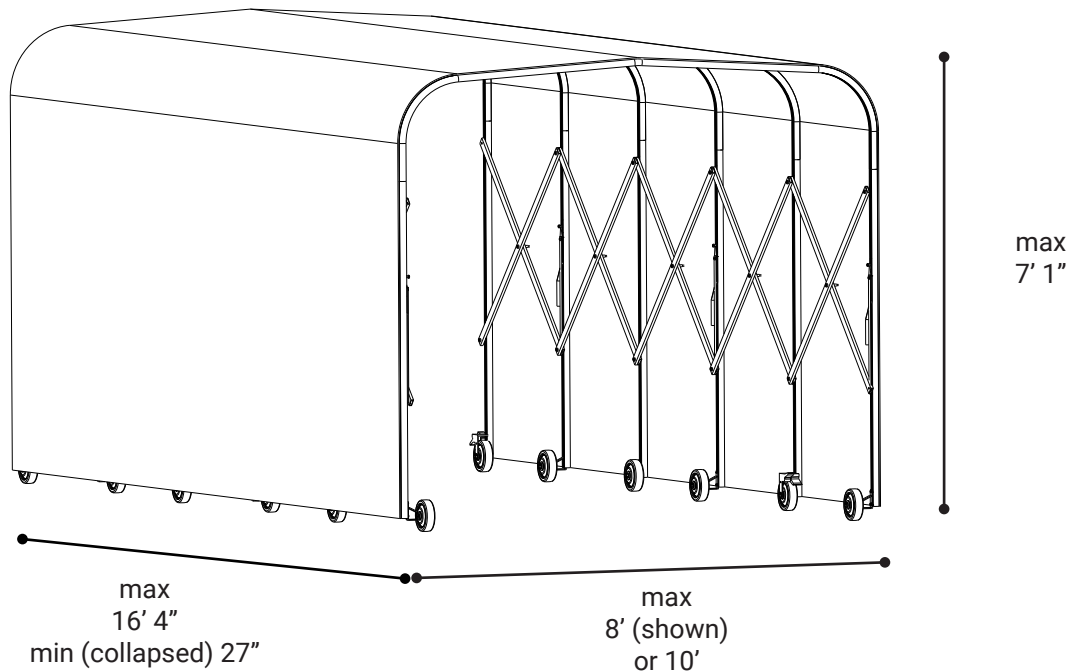

Tools and hardware included:

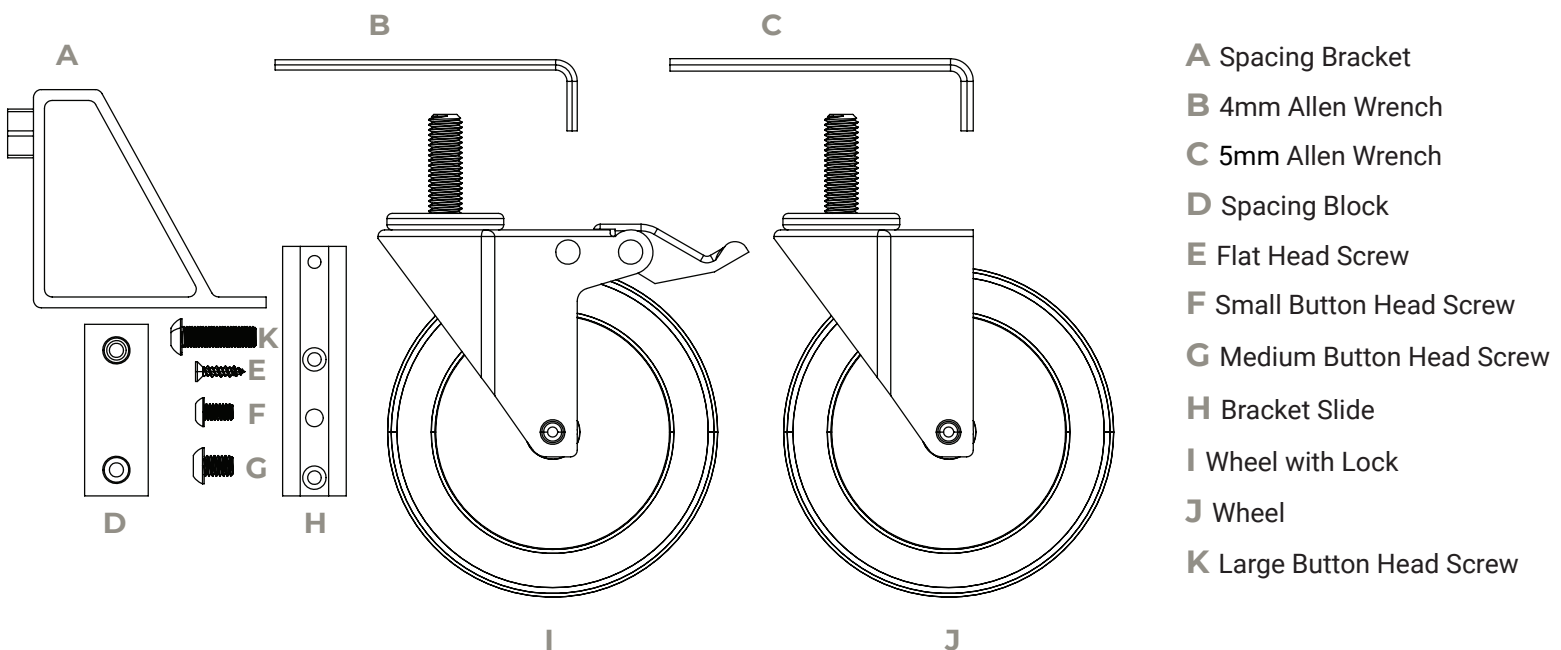

Order of wheels and Bracket Types

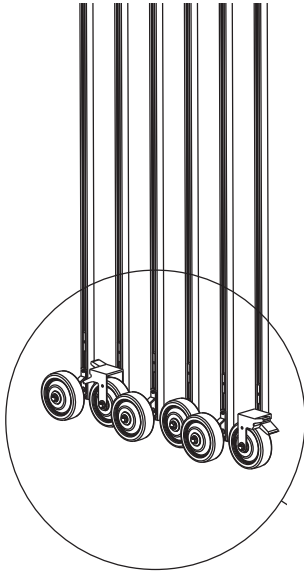

Note: All parts and fabric covering not shown for assembly clarity

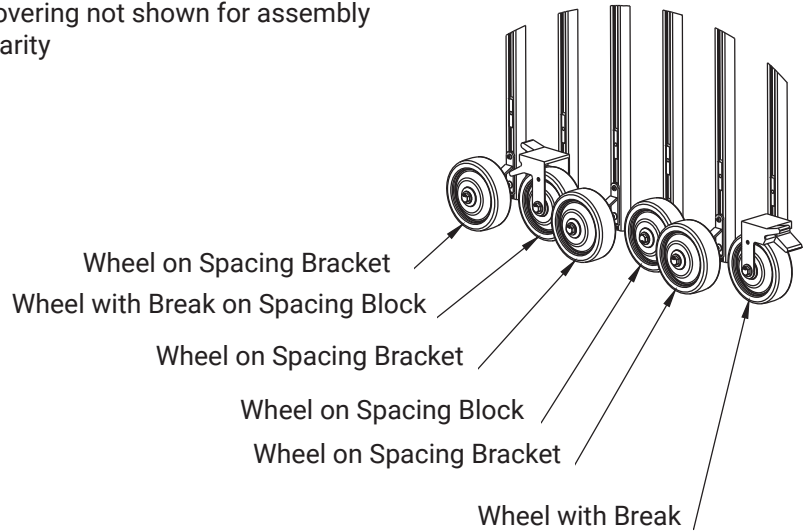

Bracket Assembly 1

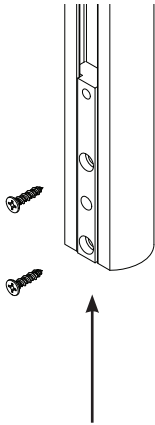

Insert Bracket Slide (H) into the bottom of the tunnel leg. Use two Flat Head Screws (E) to secure.

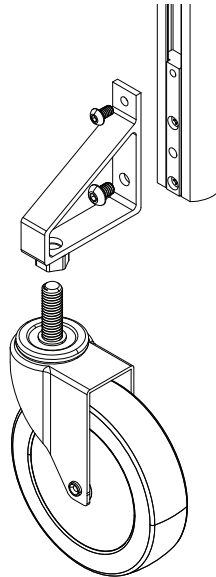

Align the holes of the Spacing Bracket (A) with the holes of the Bracket Slide (H) and use one Small Button Head screw (F) and one Medium Button Head Screw (G) to secure it.

Screw in desired wheel type.

Bracket Assembly 2

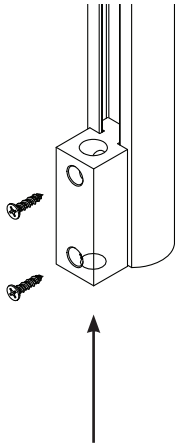

Insert Spacing Block (D) into the bottom of the tunnel leg. Use two Flat Head Screws (E) to secure.

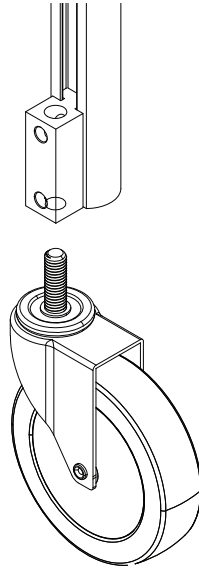

Screw in desired wheel type.

Attaching Top to Walls

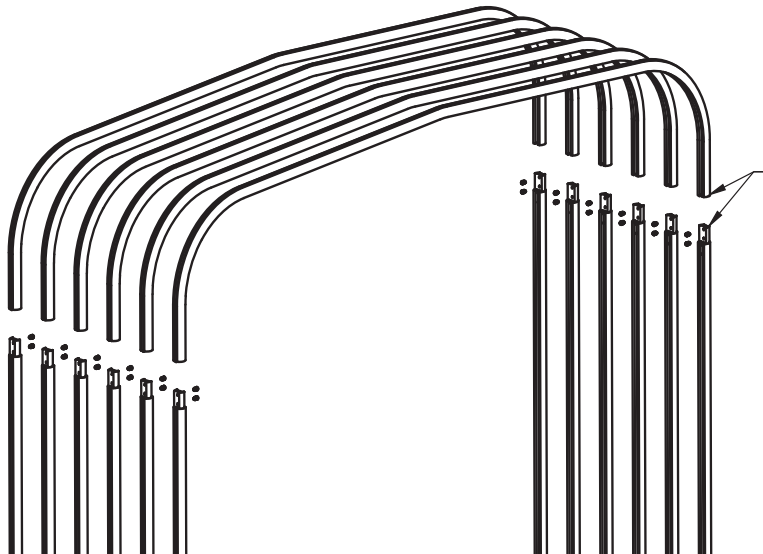

To assemble top to two sides, slide top and side rails together and install 2 each Large Button Head screws (K) with 4mm (B) Allen wrench in each post assembly

Note: All parts and fabric covering not shown for assembly clarity

Expanding and locking your shelter

Pull the Portable Equipment Shelter into extended position.

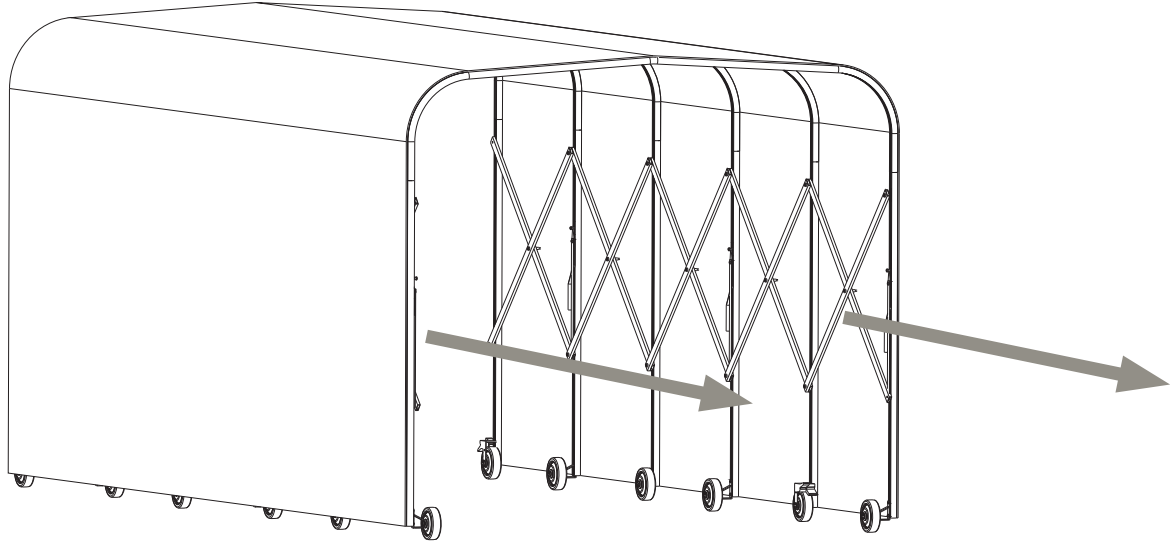

Latch handle hook over bolt and lock handle in a downward position.

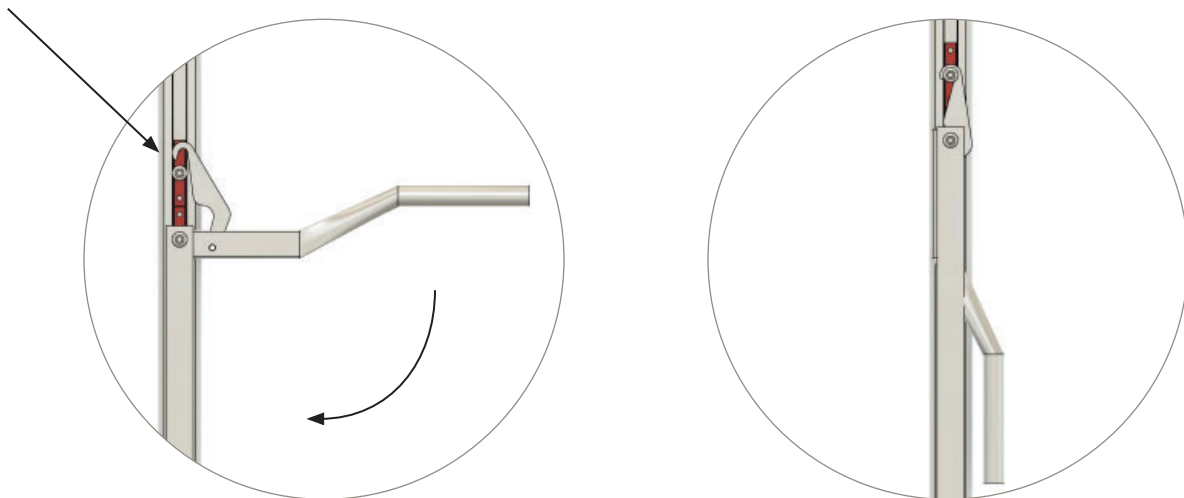

Step 5 Attaching Fabric Door Covers

To attach Fabric Doors, place onto frame and zipper sides. Smooth Velcro overlap.

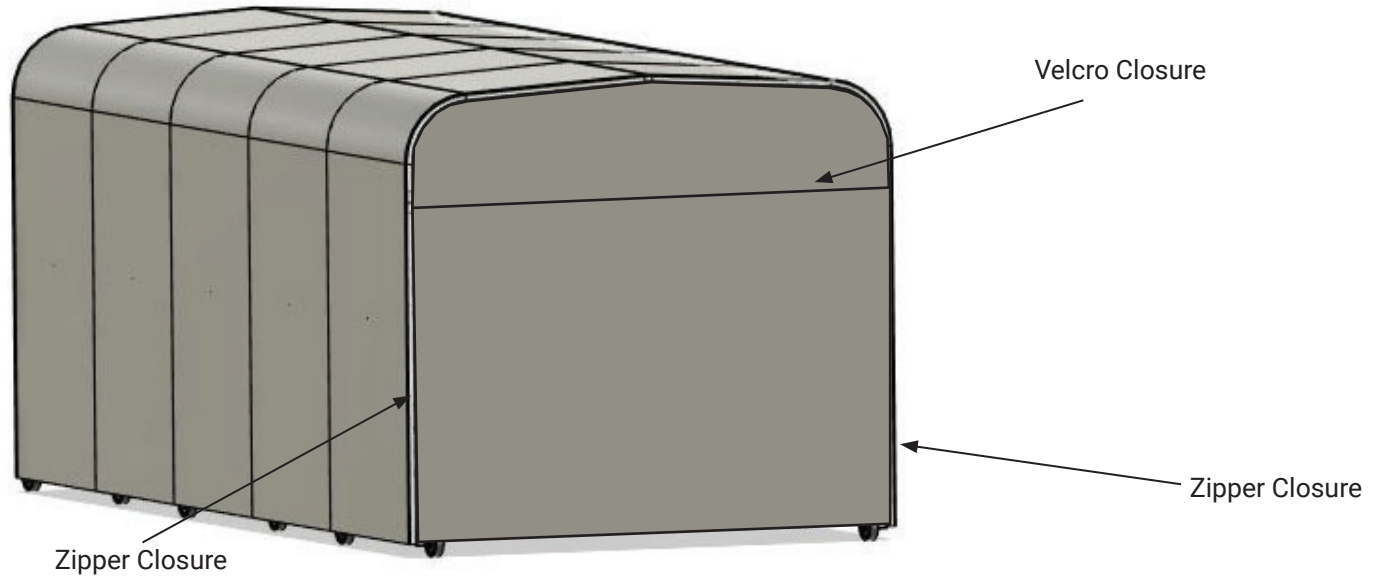

Assembly complete!
We hope you enjoy your new Portable Equipment Shelter!

For questions regarding your Portable Equipment Shelter please contact us at
1-588-457-1473 or
customerservice@versare.com



Versare Solutions, LLC
3236 California St. NE • Minneapolis, MN 55418
1-855-457-1473 • customerservice@versare.com