

QuickWall Folding Portable Partition Assembly Instructions

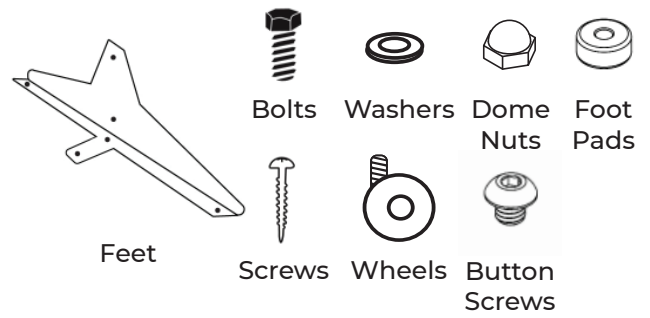

Hardware included:



If not using wheels skip to step 4.

1.

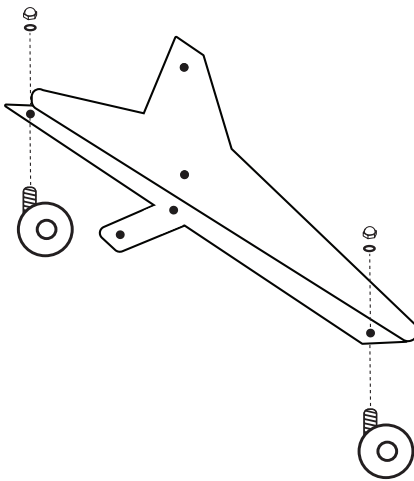

If wheels are desired, screw two wheels onto each foot with one washer and one dome nut per wheel. If not using wheels skip to step 4.

2.

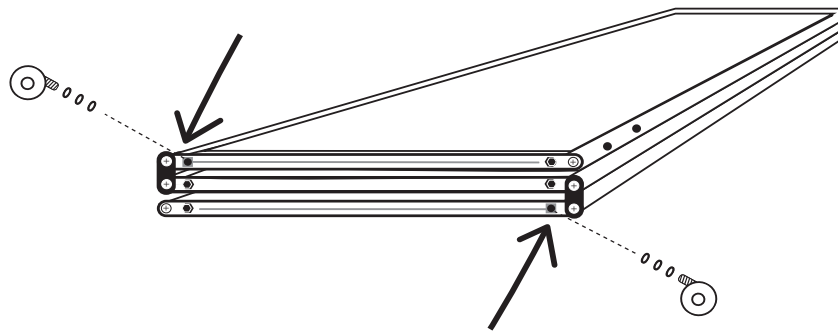

To attach wheel to panel, locate square nut in bottom track of outer panel and slide to outer edge. Add three washers to wheel threading and screw into square nut. Repeat for remaining wheels.

3.

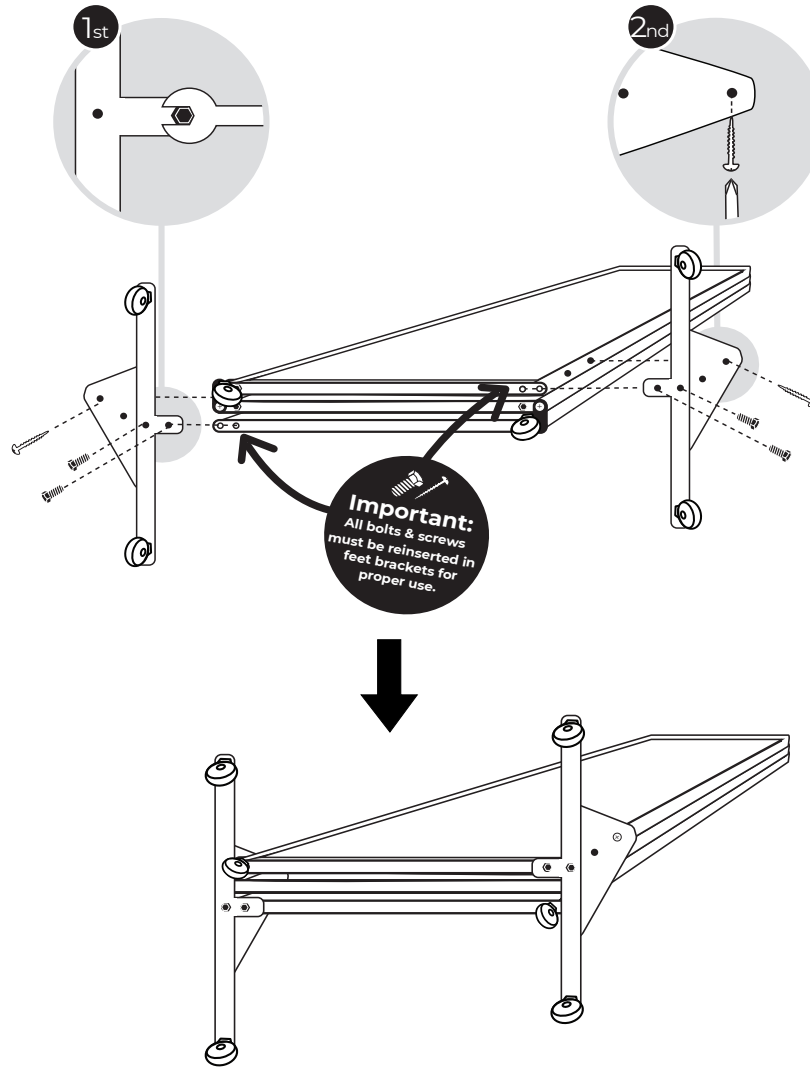

Remove two bolts from outside, bottom edge of each outer panel and one screw from the side of each outer panel. Then attach foot base with **bolts first**, screws second. Repeat for other side. Assembly complete.

4.

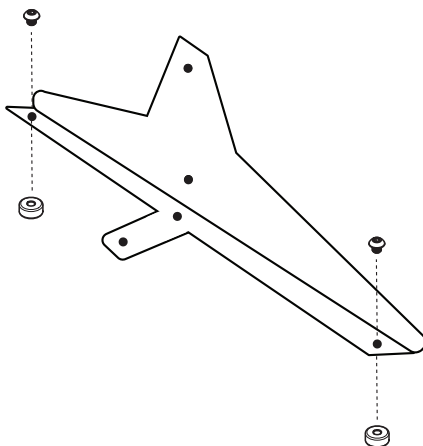

If not using wheels, insert button head screw down into foot end and secure with two washers and a nut. Repeat for other side of foot. Repeat for second foot.

5.

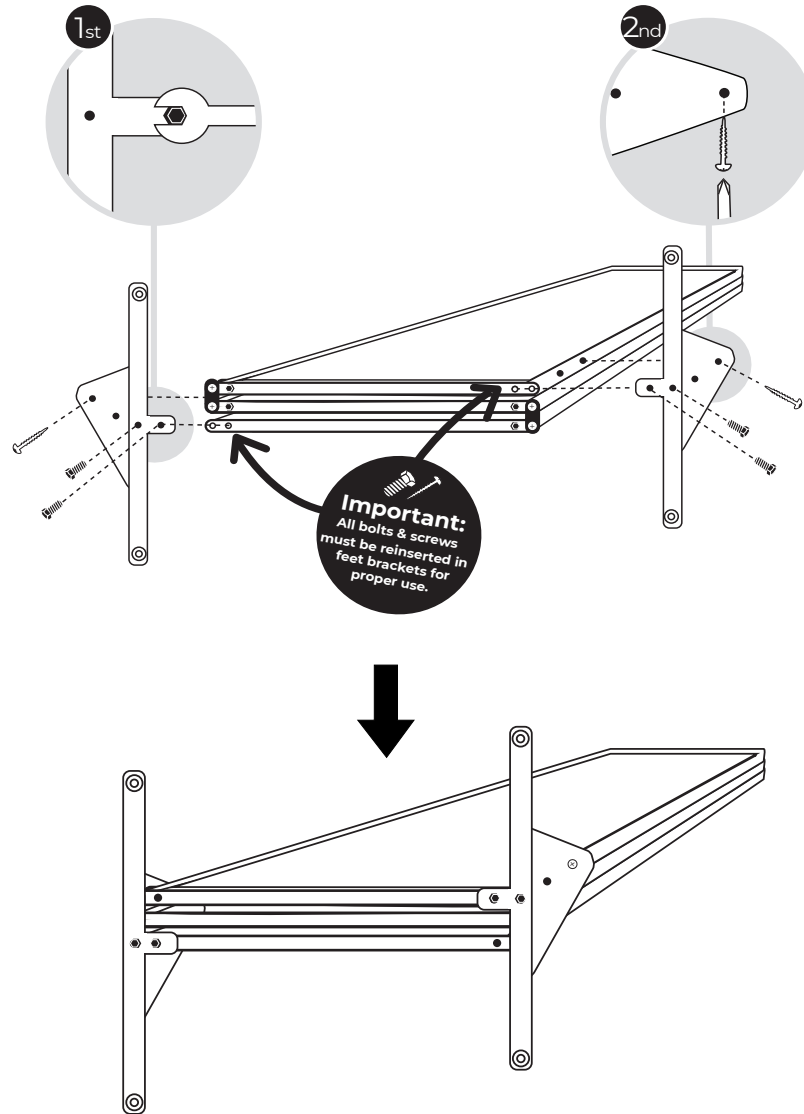

Remove two bolts from outside, bottom edge of each outer panel and one screw from the side of each outer panel. Then attach foot base with **bolts first**, screws second. Repeat for other side.

Assembly complete!

We hope you enjoy your new QuickWall Folding Portable Partition!

For questions regarding your QuickWall Folding Portable Partition please contact us at
1-855-457-1473 or
customerservice@versare.com



Versare Solutions, LLC
3236 California St. NE • Minneapolis, MN 55418
1-855-457-1473 • customerservice@versare.com

100029 REV D